

LIFTING EYE BOLT – PLAIN PATTERN

PART# _____

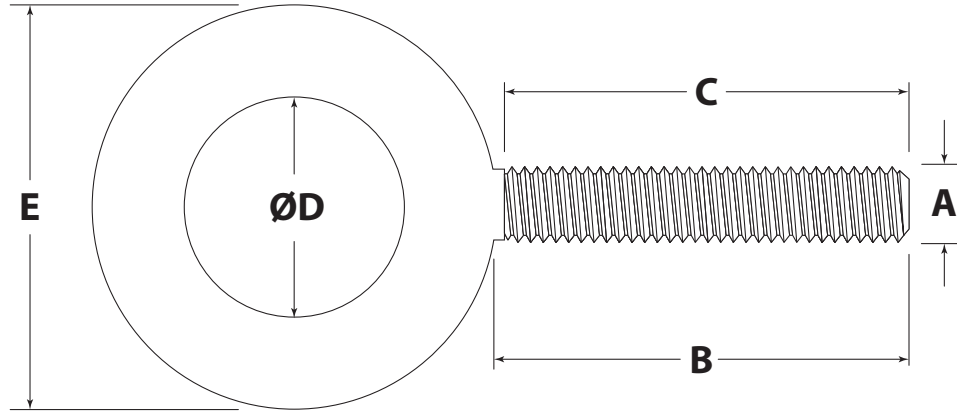

Dimension	Description	Value	Tolerance
A	Thread Diameter		Reference
B	Shank Length		+/- .125
C	Thread Length		Minimum
D	Inside Diameter		+/- .030
E	Outside Diameter		Reference

Thread Size/Pitch: _____

Material: _____ 1030-1045 Carbon Steel
 _____ 304 Stainless Steel

Finish: _____

Other Requirements: _____

For safety information, rated capacities, weight, and safe lifting practices, visit www.huyett.com/LiftingHardware.

DESIGN APPROVAL

1. All prints must be signed and approved **before** production begins.
2. Specials cannot be returned. See terms and conditions at www.huyett.com/terms.
3. Send completed prints to quotes@huyett.com.

NAME: _____

TITLE: _____

DATE: _____

SIGNATURE: _____



1215 E. 8th St.
 Minneapolis, KS 67467
 PH: 785.392.3017 Fax: 785.382.2845
www.huyett.com

Rev.	Date	Comment	Drawn By:

Note: Hot Dipped Galvanized (HDG) parts threads will be undersized prior to coating.