

LIFTING EYE NUT – METRIC DIN 582 – FORGED

PART# _____

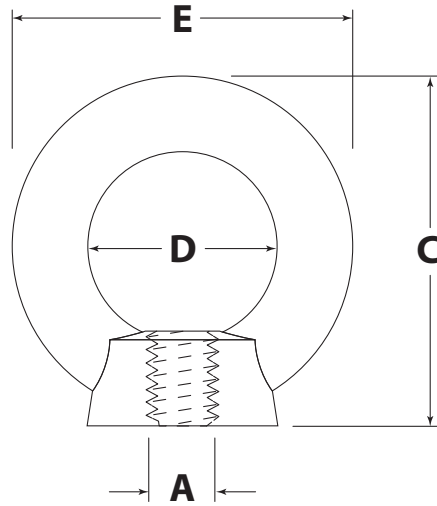

Dimension	Description	Value	Tolerance
A	Thread Diameter		Reference
C	Overall Height		Reference
D	Inside Diameter		Reference
E	Outside Diameter		Reference

Thread Size/Pitch: _____

Material: _____ 1015 Carbon Steel

Finish: _____

Other Requirements: _____

For safety information, rated capacities, weight, and safe lifting practices, visit www.huyett.com/LiftingHardware.

DESIGN APPROVAL

1. All prints must be signed and approved **before** production begins.
2. Specials cannot be returned. See terms and conditions at www.huyett.com/terms.
3. Send completed prints to quotes@huyett.com.

NAME: _____

TITLE: _____

DATE: _____

SIGNATURE: _____



1215 E. 8th St.
 Minneapolis, KS 67467
 PH: 785.392.3017 Fax: 785.382.2845
www.huyett.com

Rev.	Date	Comment	Drawn By:

Note: Unless otherwise requested, the drilled or tapped holes on Hot Dipped Galvanized (HDG) parts may be plain or plated at manufacturer's option. If plated the threads will be oversized prior to coating.

Lifting Eye Bolt Tolerances - Metric DIN 580

Material	Thread Diameter (A)	Shank Length (B) Nominal	Shank Length Min	Shank Length Max	Shank Length (B) Tolerance	ID (D) Nominal	ID Min	ID Max	ID (D) Tolerance	OD (E) Nominal	OD Min	OD Max	OD (E) Tolerance
CS	M6	13	12.65	13.35	+0.35/-0.35	20	19.1	20.5	+0.5/-0.9	36	35.5	37.1	+1.1/-0.5
CS	M8	13	12.65	13.35	+0.35/-0.35	20	19.1	20.5	+0.5/-0.9	36	35.5	37.1	+1.1/-0.5
CS	M10	17	16.65	17.35	+0.35/-0.35	25	24.1	25.5	+0.5/-0.9	45	44.5	46.1	+1.1/-0.5
CS	M12	20.5	20.08	20.92	+0.42/-0.42	30	29.1	30.5	+0.5/-0.9	54	53.5	55.1	+1.1/-0.5
CS	M14	27	26.58	27.42	+0.42/-0.42	35	33.9	35.5	+0.5/-1.1	63	62.5	64.1	+1.1/-0.5
CS	M16	27	26.58	27.42	+0.42/-0.42	35	33.9	35.5	+0.5/-1.1	63	62.5	64.1	+1.1/-0.5
CS	M18	30	29.58	30.42	+0.42/-0.42	40	38.9	40.5	+0.5/-1.1	72	71.5	73.1	+1.1/-0.5
CS	M20	30	29.58	30.42	+0.42/-0.42	40	38.9	40.5	+0.5/-1.1	72	71.5	73.1	+1.1/-0.5
CS	M22	36	35.5	36.5	+0.5/-0.5	50	48.8	50.6	+0.6/-1.2	90	89.4	91.2	+1.2/-0.6
CS	M24	36	35.5	36.5	+0.5/-0.5	50	48.8	50.6	+0.6/-1.2	90	89.4	91.2	+1.2/-0.6
CS	M27	45	44.5	45.5	+0.5/-0.5	60	58.7	60.7	+0.7/-1.3	108	107.3	109.5	+1.5/-0.7
CS	M30	45	44.5	45.5	+0.5/-0.5	60	58.7	60.7	+0.7/-1.3	108	107.3	109.5	+1.5/-0.7
CS	M33	54	53.5	54.5	+0.5/-0.5	70	68.5	70.7	+0.7/-1.5	126	125.2	127.7	+1.7/-0.8
CS	M36	54	53.5	54.5	+0.5/-0.5	70	68.5	70.7	+0.7/-1.5	126	125.2	127.7	+1.7/-0.8
CS	M42	63	62.4	63.6	+0.6/-0.6	80	78.5	80.7	+0.7/-1.5	144	143.2	145.7	+1.7/-0.8
CS	M48	68	67.4	68.6	+0.6/-0.6	90	88.3	90.8	+0.8/-1.7	166	164.9	168.1	+2.1/-1.1
CS	M56	78	77.4	78.6	+0.6/-0.6	100	98.1	100.9	+0.9/-1.9	184	182.8	186.4	+2.4/-1.2
CS	M64	90	89.3	90.7	+0.7/-0.7	110	107.9	111.1	+1.1/-2.1	206	204.8	208.4	+2.4/-1.2
CS	M80	112	111.3	112.7	+0.7/-0.7	160	157.3	161.3	+1.3/-2.7	296	294.3	299.3	+3.3/-1.7
CS	M100	130	129.2	130.8	+0.8/-0.8	180	177	181.5	+1.5/-3	330	328.3	333.3	+3.3/-1.7
SS	M6	13	12.65	13.35	+0.35/-0.35	20	19.1	20.5	+0.5/-0.9	36	35.5	37.1	+1.1/-0.5
SS	M8	13	12.65	13.35	+0.35/-0.35	20	19.1	20.5	+0.5/-0.9	36	35.5	37.1	+1.1/-0.5
SS	M10	17	16.65	17.35	+0.35/-0.35	25	24.1	25.5	+0.5/-0.9	45	44.5	46.1	+1.1/-0.5
SS	M12	20.5	20.08	20.92	+0.42/-0.42	30	29.1	30.5	+0.5/-0.9	54	53.5	55.1	+1.1/-0.5
SS	M16	27	26.58	27.42	+0.42/-0.42	35	33.9	35.5	+0.5/-1.1	63	62.5	64.1	+1.1/-0.5
SS	M20	30	29.58	30.42	+0.42/-0.42	40	38.9	40.5	+0.5/-1.1	72	71.5	73.1	+1.1/-0.5
SS	M24	36	35.5	36.5	+0.5/-0.5	50	48.8	50.6	+0.6/-1.2	90	89.4	91.2	+1.2/-0.6

Lifting Eye Nut Tolerances - Metric DIN 582

Material	Thread Diameter (A)	Overall Height (C) Nominal	Overall Height Min	Overall Height Max	Overall Height (C) Tolerance	ID (D) Nominal	ID Min	ID Max	ID (D) Tolerance	OD (E) Nominal	OD Min	OD Max	OD (E) Tolerance
CS	M6	36	35.5	37.1	+1.1/-0.5	20	19.1	20.5	+0.5/-0.9	36	35.5	37.1	+1.1/-0.5
CS	M8	36	35.5	37.1	+1.1/-0.5	20	19.1	20.5	+0.5/-0.9	36	35.5	37.1	+1.1/-0.5
CS	M10	45	44.5	46.1	+1.1/-0.5	25	24.1	25.5	+0.5/-0.9	45	44.5	46.1	+1.1/-0.5
CS	M12	53	52.5	54.1	+1.1/-0.5	30	29.1	30.5	+0.5/-0.9	54	53.5	55.1	+1.1/-0.5
CS	M14	62	61.5	63.1	+1.1/-0.5	35	33.9	35.5	+0.5/-1.1	63	62.5	64.1	+1.1/-0.5
CS	M16	62	61.5	63.1	+1.1/-0.5	35	33.9	35.5	+0.5/-1.1	63	62.5	64.1	+1.1/-0.5
CS	M20	71	70.5	72.1	+1.1/-0.5	40	38.9	40.5	+0.5/-1.1	72	71.5	73.1	+1.1/-0.5
CS	M22	90	89.4	91.2	+1.2/-0.6	50	48.8	50.6	+0.6/-1.2	90	89.4	91.2	+1.2/-0.6
CS	M24	90	89.4	91.2	+1.2/-0.6	50	48.8	50.6	+0.6/-1.2	90	89.4	91.2	+1.2/-0.6
CS	M27	109	108.3	110.5	+1.5/-0.7	60	58.7	60.7	+0.7/-1.3	108	107.3	109.5	+1.5/-0.7
CS	M30	109	108.3	110.5	+1.5/-0.7	60	58.7	60.7	+0.7/-1.3	108	107.3	109.5	+1.5/-0.7
CS	M33	128	127.2	129.7	+1.7/-0.8	70	68.5	70.7	+0.7/-1.5	126	125.2	127.7	+1.7/-0.8
CS	M36	128	127.2	129.7	+1.7/-0.8	70	68.5	70.7	+0.7/-1.5	126	125.2	127.7	+1.7/-0.8
SS	M6	36	35.5	37.1	+1.1/-0.5	20	19.1	20.5	+0.5/-0.9	36	35.5	37.1	+1.1/-0.5
SS	M8	36	35.5	37.1	+1.1/-0.5	20	19.1	20.5	+0.5/-0.9	36	35.5	37.1	+1.1/-0.5
SS	M10	45	44.5	46.1	+1.1/-0.5	25	24.1	25.5	+0.5/-0.9	45	44.5	46.1	+1.1/-0.5
SS	M12	53	52.5	54.1	+1.1/-0.5	30	29.1	30.5	+0.5/-0.9	54	53.5	55.1	+1.1/-0.5
SS	M16	62	61.5	63.1	+1.1/-0.5	35	33.9	35.5	+0.5/-1.1	63	62.5	64.1	+1.1/-0.5
SS	M20	71	70.5	72.1	+1.1/-0.5	40	38.9	40.5	+0.5/-1.1	72	71.5	73.1	+1.1/-0.5
SS	M24	90	89.4	91.2	+1.2/-0.6	50	48.8	50.6	+0.6/-1.2	90	89.4	91.2	+1.2/-0.6